

TRAFFIC LOGIX® SAFEPACE® 450 PRODUCT SPECIFICATIONS

Radar Sign Specifications



SafePace® 450 Product Specifications

Copyright © 2014-2018 Traffic Logix Corporation. All rights reserved.

This manual may not be copied in whole or in part, nor transferred to any other media or language, without the express written consent of Traffic Logix Corporation.

This document is supplied as a guide for the SafePace 450 product. Reasonable care has been taken in preparing the information it contains. However, it is possible that this document contains omissions, technical inaccuracies, or typographical errors. Product specifications are subject to change without notice and should not be considered commitments by Traffic Logix Corporation. Traffic Logix Corporation does not accept responsibility of any kind for customers' losses due to the use of this document.

Trademarks

Traffic Logix® and SafePace® are registered trademarks of Logix ITS Inc. All other product and company names are trademarks or registered trademarks of their respective owners.

This document may contain confidential and proprietary information of Traffic Logix Corporation and/or other third parties which is protected by copyright, trade secret and trademark law and may not be provided or otherwise made available without prior written authorization.

Document created: 4:57 PM on Thursday, September 20, 2018

Document version: 2.3

Traffic Logix Corporation
3 Harriet Lane
Spring Valley, NY
USA 10977

Tel: 1 (866) 915-6449
Fax: 1 (866) 995-6449
Web: www.trafficlogix.com
Email: info@trafficlogix.com

TABLE OF CONTENTS

Dimensions	4
Technical Specifications	5
Communications	7
Programming	7
Data Collection, Statistical Analysis and Reporting (optional feature)	8
Universal Mounting Bracket System	9
Warranty	10

DIMENSIONS

- » Digits: 15.0"(h) x 8.0"(w), 112 LEDs per digit
- » Text:
 - Full Size: Letters 6.0"(h) spell "YOUR SPEED" fixed message, 2 lines
 - Compact Size: Letters 4.0" (h) spell "YOUR SPEED" fixed message, 1 line
- » Unit alone: 21.5"(h) x 26.0"(w) x 3.5"(d)
- » Unit with "YOUR SPEED" sign mounted:
 - Full Size: 40.0"(h) x 30.0"(w) x 3.5"(d)
 - Compact Size: 28.0"(h) x 28.0"(w) x 3.5"(d)
- » Sign Weight (unit alone without "YOUR SPEED" sign)
 - AC Powered Model: 18 lbs
 - Battery Powered Model: 22 lbs
 - Solar Powered Model: 20 lbs (does not include solar panel or solar panel bracket)
- » Accessories
 - Lithium-ion Battery: 4 lbs
 - Universal Mounting Bracket System
 - Sign Bracket: 2 lbs
 - Pole Bracket: 5 lbs

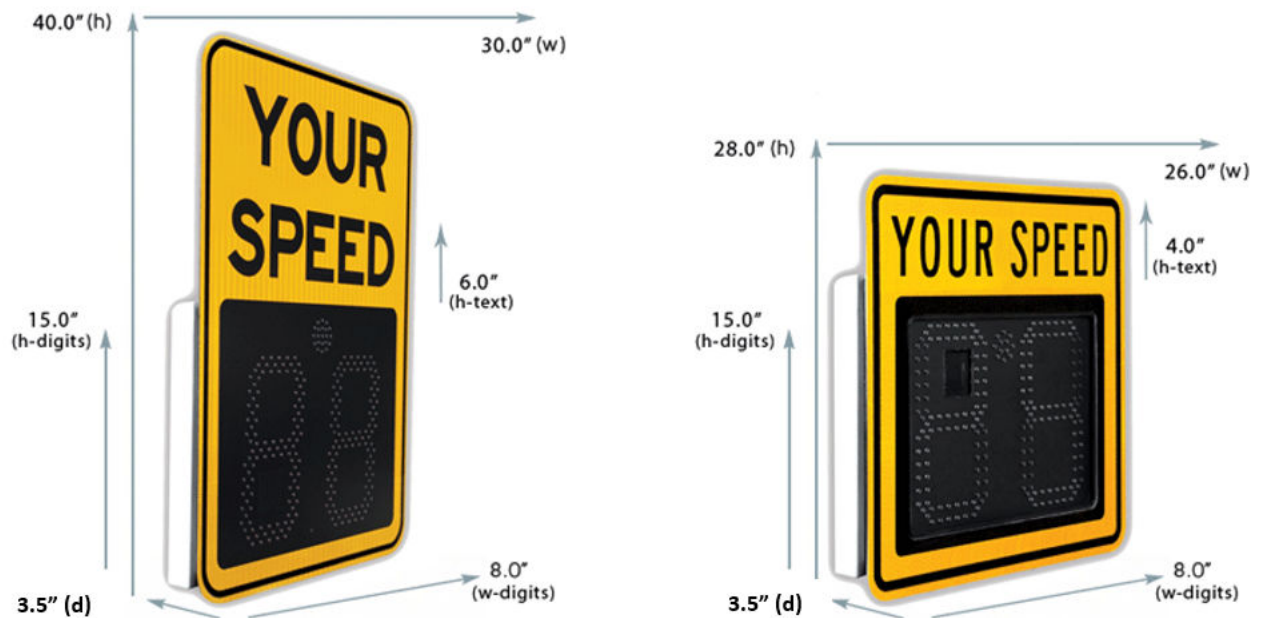

All Specifications Subject to Change Without Notice

TECHNICAL SPECIFICATIONS

- » Miles Per Hour (mph) or Kilometers Per Hour (km/h)
- » Aluminum protective cover: 0.1875" (d)
- » Yellow or white high-Intensity prismatic reflective sheeting on the sign face with black colored text
- » MUTCD approved colors and format
- » Operating Temperatures F (C): -40° (-40°) to 185° (85°)
- » Conformal coating on all circuit boards

Power

- » Power input:
 - 100~240 V AC @ 150 mA
 - 12 V DC (11-14.5 V @ 1A)
 - Built in ambient light sensing and automatic brightness control
 - Wireless battery charge monitoring (via software interface)
- » Power Options
 - AC power input: 100~240 V AC
 - DC power input: 12 V DC
 - Solar power: 50W, 90W solar panel

Radar

- » Internal Radar: Doppler (FCC approved)
- » Model: DF 300
- » Radar RF out: 5 mW maximum
- » Radar f-center: 24.125 GHz center +/- 25 MHz
- » Pickup distance: Up to 1,200 feet
- » Beam angle: 24° (vertical) x 12° (horizontal)
- » Beam polarization: Linear

Display

- » LEDs 245:
 - Digits: 224 Amber, 23°, 5 mm, luminous Intensity (5,000 – 12,000 mcd/LED)
 - Speed Violator Strobe: 21 White, 15°, 5 mm , luminous intensity (18,000 – 28,000 mcd/LED)
- » Optical lenses: 245 lenses
- » Ambient light sensor and automatic brightness adjustment

Enclosure

- » 12 gauge aluminum, flat black powder coated front for reduced glare and maximum contrast; light gray powder coated body to minimize heat absorption
- » Weatherproof, NEMA 4X-12, IP65 level compliant
- » Non-sealed and ventilated

Mounting Options

- » Banding brackets (standard)
- » Universal Mounting Bracket System
 - Universal mounting options: circular, square and telspar poles
 - Theft resistant
 - Promotes sign portability: sign locks into mounting bracket with a turn of a key

All Specifications Subject to Change Without Notice

COMMUNICATIONS

- » Bluetooth (standard)
- » GSM/GPRS (optional, for use with SafePace Cloud)



PROGRAMMING

- » SafePace® Pro management software
- » SafePace® Cloud remote management
- » 24/7 365 day programming and scheduling
- » Display Settings:
 - Display On/Stealth Modes (In Stealth Mode, speed is not displayed but data is collected)
 - Display Closest/Fastest Vehicle Speed
 - Digit Flashing Speed Threshold (digits flash above specified speed threshold)
 - LEDs Flashing Speed (for digits)
 - Fast: 1.5 Hz
 - Medium: 1 Hz
 - Slow: 0.75 Hz
 - Speed Violator Strobe (pulsing strobe flashes above specified speed)



All Specifications Subject to Change Without Notice

DATA COLLECTION, STATISTICAL ANALYSIS AND REPORTING (OPTIONAL FEATURE)

- » Traffic data collected and stored by location
- » Stealth Mode (captures baseline traffic data with speed display turned off)
- » Download through wireless connection
- » Statistical Reporting & Charts
 - Summary Reports
 - Weekly Reports
 - Period Comparison Reports
 - Full custom reports and charts
 - Reporting Parameters:
 - Average Vehicle Count
 - Total Vehicle Count
 - Average Speed
 - Average Number of Speed Violations
 - Total Number of Speed Violations
 - Other Features:
 - Minimum and Maximum Speed
 - 85th Percentile Speed
 - Counters by Speed Bins
 - 5 units (MPH or KM/H) Speed Bin Resolution
 - Reports print directly or can be exported into CSV format, MS Excel, Adobe Acrobat PDF and HTML
 - Charts may be printed directly or converted into Adobe Acrobat PDF and image formats



UNIVERSAL MOUNTING BRACKET SYSTEM

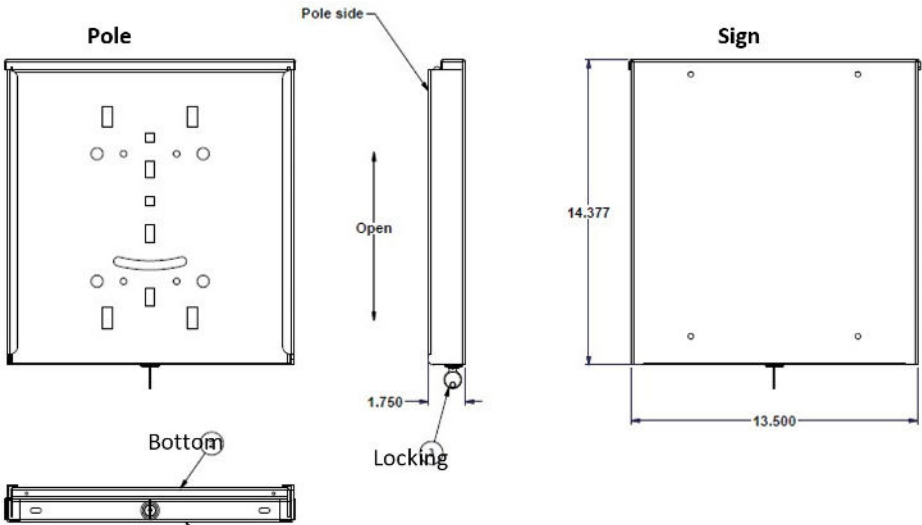

Inside View

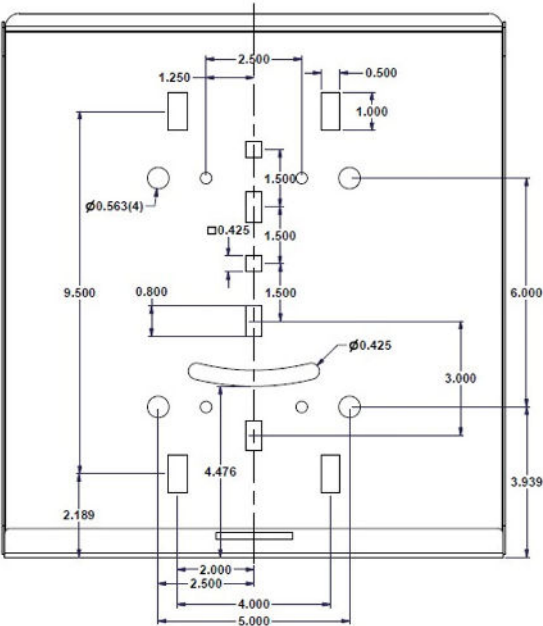

WARRANTY



Two Year Warranty

Two year warranty on parts and labor
excluding damage related to
vandalism, abuse, and/or theft

Subject to the following conditions, Traffic Logix Corporation (“Traffic Logix”) warrants that the SafePace 450 sign (the “Product”) is free from defects in materials and workmanship.

This limited warranty begins on the invoice date of your purchase of the Product and extends:

- » For TWO (2) calendar years on the sign, and
- » For ONE (1) calendar year on the batteries.

This limited warranty extends only to the original purchaser of the Product when purchased either directly through Traffic Logix or through an authorized Traffic Logix distributor and is not assignable or transferable to any subsequent purchaser or end-user. Traffic Logix’s obligation and liability under this warranty are expressly limited to repairing or replacing, at Traffic Logix’s option, defective products. In no circumstances shall Traffic Logix’s liability, whether in contract or tort, under any warranty, in negligence, or otherwise, exceed the amount of the purchase price of the product. Traffic Logix shall not be liable for special, indirect, or consequential damages of any kind. This warranty does not cover damages resulting from normal wear and tear, incorrect installation or operation, use other than for the product’s intended purposes, vandalism, and extraordinary environmental circumstances. Traffic Logix reserves the right to charge for these damages to the product at rates normally charged for repairing such products not covered under this warranty. Damages resulting from any physical changes or alterations made to the product other than Traffic Logix will render this warranty **VOID**. Using any parts or accessories not supplied or approved by Traffic Logix, such as battery chargers, will further render the warranty **VOID**.

Traffic Logix neither assumes, nor authorizes any person to assume for it, any other liability in connection with the sale of the Product, and there are no agreements or warranties collateral to or affecting this limited warranty.

THE LIMITED WARRANTY SET FORTH IN THIS AGREEMENT IS THE EXCLUSIVE AND SOLE WARRANTY APPLICABLE TO THIS PURCHASE. ALL OTHER WARRANTIES, EXPRESS OR IMPLIED, INCLUDING, BUT NOT LIMITED TO THE IMPLIED WARRANTY OF MERCHANTABILITY AND THE IMPLIED WARRANTY OF FITNESS FOR A PARTICULAR PURPOSE ARE EXPRESSLY DISCLAIMED.

Traffic Logix does not warrant that any of its products will meet or comply with the requirements of any applicable federal, state or local safety code, law, regulation or ordinance (“Applicable Safety Laws”). Buyer acknowledges that Traffic Logix’s products are to be used only in accordance with the attached Conditional Terms of Use and any Applicable Safety Laws. Buyer agrees that there shall be no coverage or benefits of any kind under this limited warranty if it is determined by Traffic Logix that the Product was not installed or used in accordance with the Conditional Terms of Use or Applicable Safety Laws, or if the Product has been

altered in any way by anyone other than Traffic Logix, or if the Product has been subject to any misuse or accident. In addition, Buyer assumes and agrees to indemnify Traffic Logix for all risk, liability or expense that results from any installation or use of the Product that is not in accordance with the Conditional Terms of Use or any Applicable Safety Laws.

Warranty Replacement Procedure

In order to submit a claim for the repair or replacement of the Product under this limited warranty, proceed as follows:

1. Contact Technical Support. **Do NOT** ship your defective product to Traffic Logix prior to contacting Technical Support.
2. A Technical Support Agent will evaluate the Product to determine if it is defective. You may be required to do some troubleshooting as part of this evaluation.
3. If the Product is defective, then you will need to submit your contact information, and proof of purchase (including the date of purchase), in order to obtain repair or replacement parts.
4. The Technical Support Agent will provide you with a Return Materials Authorization number and instructions on how to have the defective parts repaired or replaced.